

Drum Type Diverter

DTD-X



AIRLOCK range of **DTD-X** diverters are designed to divert or converge dry materials such as Powders, Pellets, Kibbles, Granules **especially for abrasive products** with minimum degradation in Pneumatic Conveying.

These diverters are mainly used in Chemical, Plastics, and other process industries.

The DTD-X is available in different sizes starting from 100, 125 & 150 mm.

FEATURES :

- Dual channel
- Abrasive resistant seal
- ATEX rated
- Product contact surface is Hardened Steel upto 6mm thick (wear resistant liner)
- Aluminium Housing, Drum & End Covers
- No external moving parts
- Pressure up to 2 bar with static seals
- Air cylinder operated
- Easy maintenance
- Minimum product degradation

DESIGN :

- Sizes from 100 to 150 mm
- DIN / ANSI / JIS drilling patterns
- Operating temperature 80 deg C (Max)

OPTIONS :

- Thicker Stainless Steel liner

APPLICATION :

- ❖ Mainly designed for abrasive products
- ❖ Suitable for Powder, Granules and Pellets
- ❖ For diverting and merging of product flow in conveying line applications

PRODUCT DETAILS

Drum Type Diverter (DTD-X) is made of Aluminium thro' high quality Gravity Die Casting process.

The standard seals are Abrasive resistant which ensures the complete sealing between housing and drum.

The Diverter can be used in pressure conveying where the pressure is less than 2 bar with static seals.

The DTD-X is supplied as a complete unit with Pneumatic Cylinder and associated components like Solenoid Valve, Solenoid Coils, Junction Box and Position Sensors.

Drum Type Diverter

DTD-X

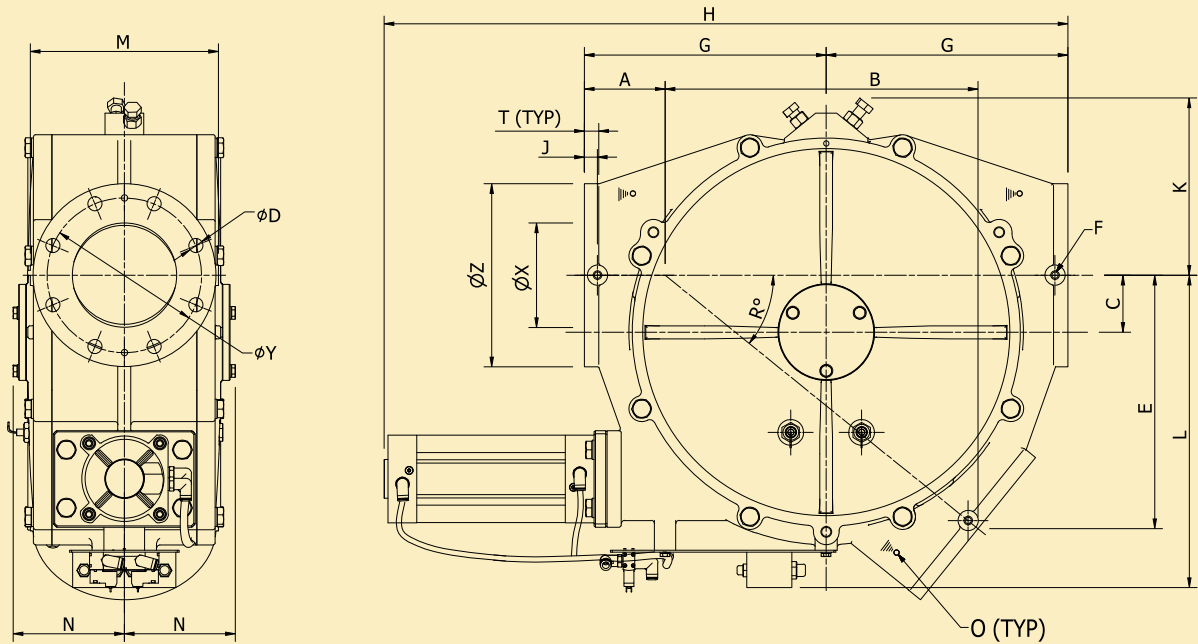

Type DTD	DIN				ANSI #150		A	B	C	E	F	G	H	J	K	L	M	N	O	T	R°
	Ø X	Ø Y	Ø D	Ø Z	Ø Y	Ø D															
100	100	180	8xØ18	228	190.5	8xØ19	-	-	-	-	M10x20	270	815	15	225	360	230	140	M10	18	-
125	125	210	8xØ18	250	215.9	8xØ22.2	-	-	-	-	M12x20	335	990	17.5	265	430	255	160	M10	20	-
150	150	240	8xØ22	284	241.3	8xØ22.2	125	486	88.5	393	M12x20	375	1061	20	295	485	292	173	M10	22	39

All dimensions are in mm.

Note: We reserve the right to modify the dimensions without prior notice.